

Distributed Systems

2a. Networking Terminology

[background information: not course material]

Paul Krzyzanowski

pxk@cs.rutgers.edu

Local Area Network (LAN)

Communications network

- small area (building, set of buildings)
- same, sometimes shared, transmission medium
- high data rate (often): 1 Mbps – 1 Gbps
- Low latency
- devices are peers
 - any device can initiate a data transfer with any other device

Most elements on a LAN are **workstations**

- endpoints on a LAN are called **nodes**

Connecting nodes to LANs



Connecting nodes to LANs

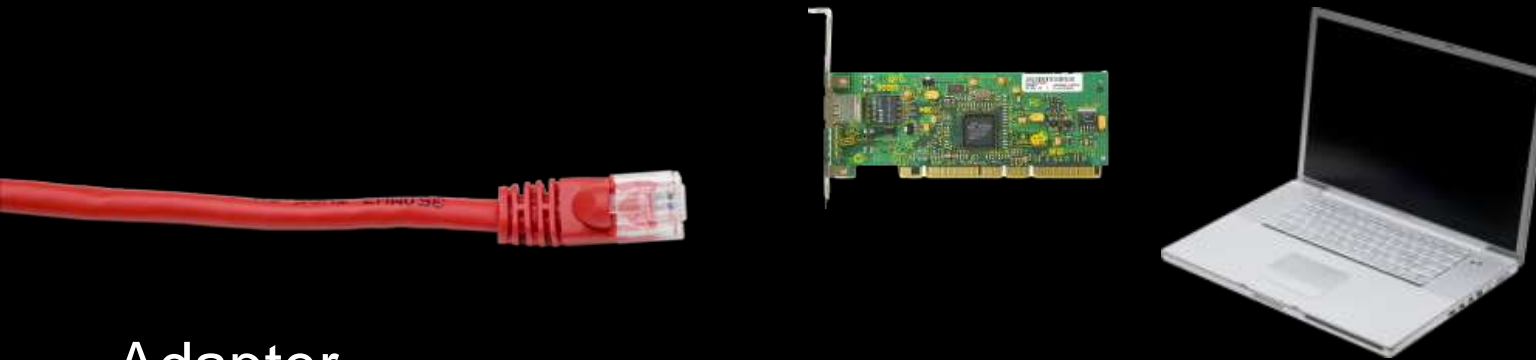

Adapter

- expansion slot (PCI, PC Card, USB dongle)
- usually integrated onto main board

Network adapters are referred to as **Network Interface Cards (NICs)** or **adapters** or **Network Interface Component** (since they're often not cards anymore)

Media

Wires (or RF, IR) connecting together the devices that make up a LAN

Twisted pair

- Most common:
 - STP: shielded twisted pair
 - UTP: unshielded twisted pair
(e.g. Telephone cable, Ethernet 100BaseT)

Coaxial cable

- Thin (similar to TV cable)
- Thick (e.g., 10Base5, ThickNet)

Fiber

Wireless

Hubs, routers, bridges

Hub

- Device that acts as a central point for LAN cables
- Take incoming data from one port & send to all other ports

Switch

- Moves data from input to output port.
- Analyzes packet to determine destination port and makes a virtual connection between the ports.

Concentrator or repeater

- Regenerates data passing through it

Bridge

- Connects two LANs or two segments of a LAN
- Connection at data link layer (layer 2)

Router

- Determines the next network point to which a packet should be forwarded
- Connects different types of local and wide area networks at network layer (layer 3)

Transmission networks

Baseband

- All nodes share access to network media on an equal basis
- Data uses entire bandwidth of media

Broadband

- Data takes segment of media by dividing media into channels (frequency bands)

Broadband/Baseband: Cable TV

Broadband

55-552 MHz: analog channels 2-78

553-865 MHz: digital channels 79-136

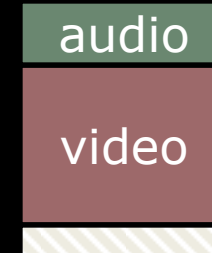

Baseband within Broadband

DOCSIS: Data Over Cable Service Interface Specification
(approved by ITU in 1998; DOCSIS 2.0 in 2001; DOCSIS 3.0 in 2006)

Downstream: 50-750 MHz range, 6 MHz bandwidth

- up to 38 Mbps
- received by all modems

Upstream: 5-42 MHz range

- 30.72 Mbps (10 Mbps in DOCSIS 1.0, 1.1)
- data delivered in timeslots (TDM)

DOCSIS 3.0 features **channel bonding** for greater bandwidth

DOCSIS Modem

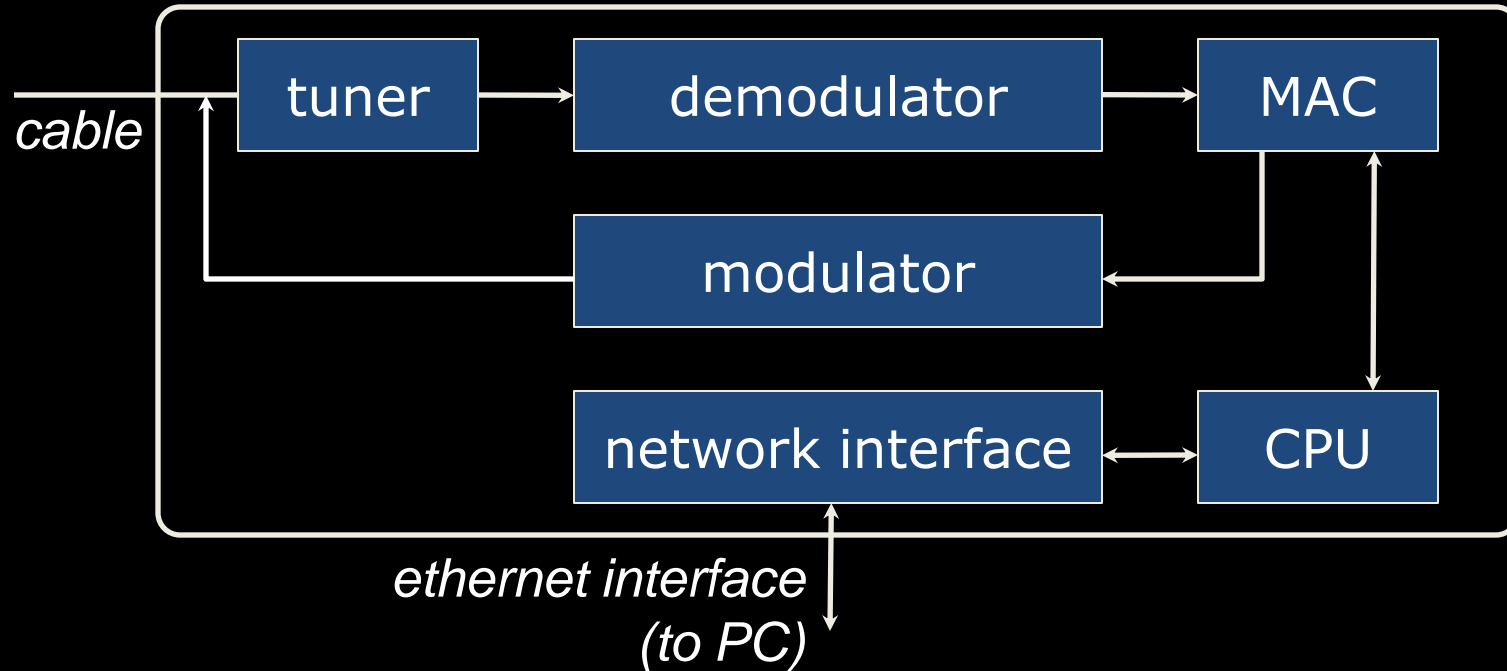

Restrictions on upload/download rates set by transferring a configuration file to the modem via TFTP when it connects to the provider.

Baseband: Ethernet

Standardized by IEEE as 802.3 standard

Speeds: 100 Mbps - 1 Gbps typical today

- Ethernet: 10 Mbps
- Fast Ethernet: 100 Mbps
- Gigabit Ethernet: 1 Gbps
- 10 Gbps, 100 Gbps

Network access method is

Carrier Sense Multiple Access with Collision Detection (CSMA/CD)

- Node first listens to network to see if busy
- Send
- Sense if collision occurred
- Retransmit if collision

Ethernet media

Bus topology (original design)

- originally thick coax (max 500m): 10Base5
- then... thin coax (<200m): 10Base2
 - BNC connector

Star topology (central hub or switch)

- 8 pin RJ-45 connector, UTP cable, 100 meters range
- 10BaseT for 10 Mbps
- 100BaseT for 100 Mbps
- 1000BaseT for 1 Gbps
- Cables
 - CAT-5: unshielded twisted pair
 - CAT-5e: designed for 1 Gbps
 - CAT-6: 23 gauge conductor + separator for handling crosstalk better

Wireless Ethernet media

Wireless (star topology)

- 802.11 (1-2 Mbps)
- 802.11b (11 Mbps - 4-5 Mbps realized)
- 802.11a (54 Mbps - 22-28 Mbps realized)
- 802.11g (54 Mbps - 32 Mbps realized)
- 802.11n (108 Mbps - 30-47 Mbps realized)



Connecting to the Internet

- DOCSIS modem via cable TV service
- DSL router
 - Ethernet converted to ATM data stream
 - Up to 20 Mbps up to ~ 2 km.
 - POTS limited to 300-3400 Hz
 - DSL operates > 3500 Hz
- Modem
 - Data modulated over voice spectrum (300-3400 Hz)
 - Serial interface to endpoint
 - V.92: 48 kbps downstream, near 56 kbps up
 - Use PPP or SLIP to bridge IP protocol

Connecting to the Internet

- Dedicated T1 or T3 line
 - T1 line: 1.544 Mbps (this used to be fast!)
(24 PCM TDMA speech lines @ 64 kbps)
 - T3 line: 44.736 Mbps (672 channels)
 - CSU/DSU at router presents serial interface
 - Channel Service Unit / Data Service Unit

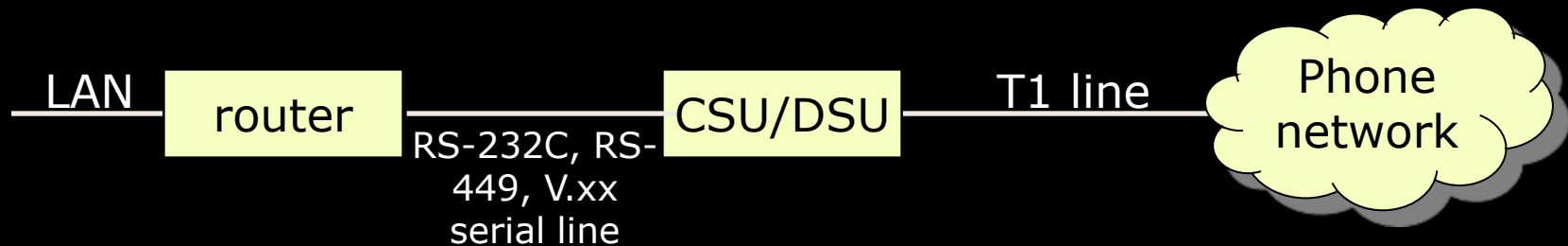

Connecting to the Internet

- **Fiber to the Home, Fiber to the Curb**
 - Ethernet interface
 - E.g., Verizon's FiOS – up to 100 Mbps to the home
- Long Reach Ethernet (**LRE**)
 - Ethernet performance up to 5,000 feet
- Wireless:
 - **WiMax**
 - **LTE** (Long Term Evolution, known as **4G**)
 - Peak downstream rate: 326.5 Mbps; Peak upstream: 86.4 Mbps
 - Support from Verizon, AT&T, T-Mobile, France Télécom, ...
 - **HSPA** (3G: 14 Mbps downlink, 5.8 Mbps uplink)
 - **HSPA+** (AT&T calls it 4G now: up to 84 Mbps downlink, 22 Mbps uplink)
 - **EDGE** (2G: 70-135 Kbps)
 - **GPRS** (<32 Kbps)

The End